

# IQS-2400

R&D AND MANUFACTURING—OPTICAL



- C- and L-band use
- +13 dBm output power
- $\pm 0.01$  nm accuracy
- Outstanding wavelength stability
- Ideal for EDFA testing

## High-Accuracy WDM Laser Source

The IQS-2400 WDM Laser Source offers high accuracy and stability for testing the power and spectral sensitivity of active components, passive components and WDM building blocks.

### Unequaled long-term wavelength stability

The IQS-2400 emulates ITU-T channels in dense WDM applications such as multiwavelength network simulation, simultaneous multiple inputs for EDFA characterization and insertion loss measurement of DWDM passive components. This source is ideal for the production environment offering unmatched, long-term wavelength stability. The  $\pm 0.01$  nm absolute accuracy enables the IQS-2400 WDM Laser Source to replace a wavelength measurement instrument when testing components or systems. The IQS-2400 features wavelength-tuning capabilities around each of the ITU-T grid wavelengths, dithering up to 300 kHz with a triangular or square waveform, and an output power reaching 13 dBm with a 10 dB attenuation range. DFB laser diode manufacturers have the option of providing their own DFBs.

### Multifunctional flexibility to match your needs

The IQS-2400 WDM Laser Source can operate in four different modes: Normal, High-Wavelength Stability, Dithering and On/Off. Normal mode provides access to total wavelength and power tuning ranges, maintaining full control of the output power (automatic power control). From a set point in wavelength and power levels, High-Wavelength Stability mode provides finer wavelength and power tuning resolutions through laser temperature steps of  $0.01^{\circ}\text{C}$  and laser current steps of  $0.01$  mA. This mode operates the laser at a constant current (automatic current control). Since the central wavelength may drift slightly (due to aging) in Normal mode, High-Wavelength Stability mode allows for continuous access to long-term, high-accuracy wavelength set points. The last two modes, On/Off and Dithering, provide modulation capabilities from 10 Hz to 300 kHz. On/Off mode ensures maximum optical extinction when activated, while Dithering mode adds a small waveform (triangular or square) to the CW signal, thus reducing the signal coherence length. In On/Off mode, several sources can be synchronized from an external TTL signal generator or from any module's synchronization output. Therefore, each source can operate at a different frequency and amplitude or precisely in phase.



IQS-2400 WDM Laser Source

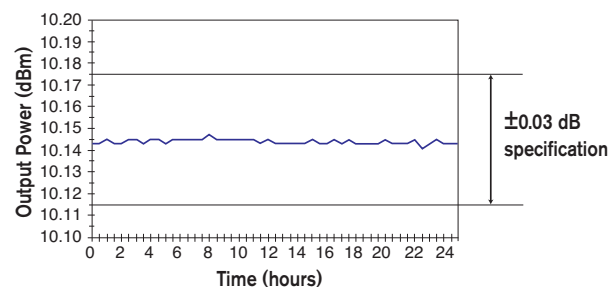

The source's excellent power stability output is ideal for long-term monitoring.

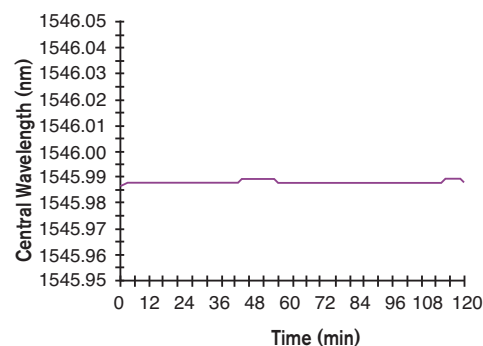

The temperature stabilization circuit ensures low central wavelength drift.

### Precise calibration for outstanding performance

The power and wavelength of each DFB laser is accurately calibrated to ensure the best possible performance and confidence in your test results. The IQS-2400's calibration setup, using its NIST-traceable wavelength meter and four-channel power meter, allows fully referenced and automated calibration of the DFB's internal temperature and laser current. A precise central wavelength at any power level can be obtained. The  $\pm 0.01$  nm absolute accuracy is one of the highest levels of accuracy available today for a laser source instrument.

### Versatile and reliable EDFA and WDM testing

Combine more than one modular IQS-2400 WDM Laser Source with an IQS-3150-B Variable Attenuator or 3150-BI Variable Attenuator (with integrated power meter), an IQS-1700X Power Meter and an IQS-5240B Optical Spectrum Analyzer in an IQS-500 Intelligent Test System. This setup enables precise, stable tones at every attenuation step throughout the complete WDM spectrum. Automatic tone balancing avoids the time-consuming and tedious manual adjustments that were once necessary to obtain a uniform input comb.

#### Comb generation, control and feedback

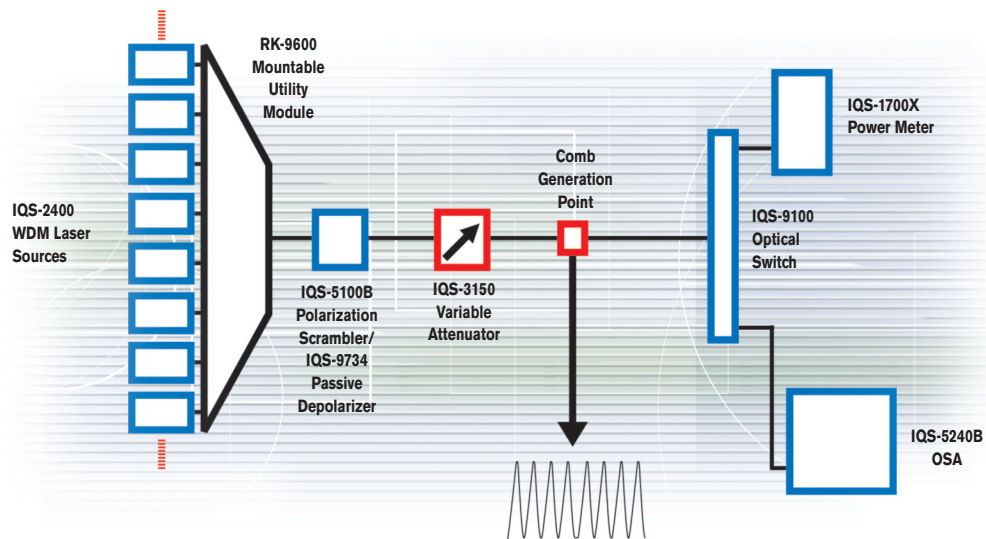

■ Typical setup for an IQS-based optical fiber amplifier test system using the IQS-2400 WDM Laser Source.

## Main screen: IQS-2400 software application

A  $\pm 1$  nm tuning range for complete optical loss/gain characterization around each ITU-T grid wavelength

Quick access to pre-selected set points

A 10 dB output power attenuation range

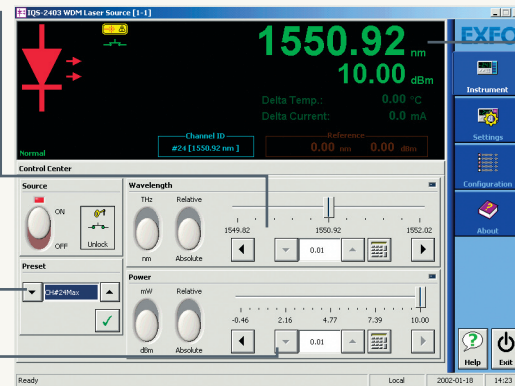

Indicator: user-defined set point for power and wavelength

## The IQS-500 Intelligent Test System

The IQS-500 Intelligent Test System provides a flexible approach to optical test and measurement for manufacturing, automation, optical qualification and R&D. It combines powerful features and control capabilities for up to 100 modules.

Based on standard industrial PC architecture, the IQS-500 Intelligent Test System is a scalable modular platform that includes controllers, expansion units and a comprehensive range of plug-in test modules. The IQS-500 is also backward-compatible with most modules from EXFO's IQ generation, allowing you to maximize the return on previous investments. The IQS-500 Intelligent Test System offers a powerful, easy-to-use environment to match your most demanding needs.

## Specifications

### IQS-2402 SPECIFICATIONS

Model		P4
Wavelength band (nm)		1308 ± 5
Wavelength tuning range (nm)		±0.5 (typical)
Wavelength tuning resolution <sup>b</sup> (nm)		0.01
Wavelength accuracy <sup>c, d</sup> (nm)		±0.01
Wavelength stability <sup>d, e</sup> (nm)		±0.002
Output power <sup>f</sup> (dBm)		10
Output power attenuation range (dB)		>6
Spectral linewidth (MHz) (typical)		<20
Sidemode suppression <sup>g</sup> (dB)		30 (40 typical)
Output power uncertainty <sup>c</sup> (dB)		±0.3
Power stability <sup>c, d</sup> (dB)	15 min	±0.005 ( $\Delta= 0.01$ )
	8 h	±0.03 ( $\Delta= 0.06$ )
Modulation frequency (internal or external sync.) (kHz)		0.010 to 300
Dithered modulation amplitude range <sup>h</sup> (mA)		1 to 5
Dithered modulation electrical waveform		Square/triangular

### IQS-2403 SPECIFICATIONS

Model		P4/P5	P6/P7
Wavelength band		C-band 1528 nm to 1565 nm	C-band 1528 nm to 1565 nm
Wavelength tuning range <sup>a</sup> (nm)		±1	±1
Wavelength tuning resolution <sup>b</sup> (nm)		0.01	0.01
Wavelength accuracy <sup>c, d</sup> (nm)		±0.01	±0.02
Wavelength stability <sup>d, e</sup> (nm)		±0.002	±0.002
Output power <sup>f</sup> (dBm)		10	13
Spectral linewidth (MHz) (typical)		<20	<20
Output power attenuation range (dB)		10	10
Sidemode suppression <sup>g</sup> (dB)		30 (40 typical)	30 (40 typical)
Output power uncertainty <sup>c</sup> (dB)		±0.3	±0.3
Power stability <sup>c, d</sup> (dB)	15 min	±0.005 ( $\Delta= 0.01$ )	±0.005 ( $\Delta= 0.01$ )
	8 h	±0.03 ( $\Delta= 0.06$ )	±0.03 ( $\Delta= 0.06$ )
Modulation frequency (internal or external sync.) (kHz)		0.010 to 300	0.010 to 300
Dithered modulation amplitude range <sup>h</sup> (mA)		1 to 5	1 to 5
Dithered modulation electrical waveform		Square/triangular	Square/triangular

## IQS-2404 SPECIFICATIONS

Model	P4/P5	P6/P7
Wavelength band	L-band 1566 nm to 1606 nm	L-band 1566 nm to 1606 nm
Wavelength tuning range <sup>a</sup> (nm)	±1	±1
Wavelength tuning resolution <sup>b</sup> (nm)	0.01	0.01
Wavelength accuracy <sup>c, d</sup> (nm)	±0.01	±0.02
Wavelength stability <sup>d, e</sup> (nm)	±0.002	±0.002
Output power <sup>f</sup> (dBm)	10	13
Output power attenuation range (dB)	10	10
Spectral linewidth (MHz) (typical)	<20	<20
Sidemode suppression <sup>g</sup> (dB)	30 (40 typical)	30 (40 typical)
Output power uncertainty <sup>c</sup> (dB)	±0.3	±0.3
Power stability <sup>c, d</sup> (dB)	15 min	±0.005 ( $\Delta= 0.01$ )
	8 h	±0.03 ( $\Delta= 0.06$ )
Modulation frequency (internal or external sync.) (kHz)	0.010 to 300	0.010 to 300
Dithered modulation amplitude range <sup>h</sup> (mA)	1 to 5	1 to 5
Dithered modulation electrical waveform	Square/triangular	Square/triangular

### Notes

- Guaranteed if the ambient temperature stays between 15 °C to 30 °C.
- In high-wavelength stability mode, better resolution is possible, but on a limited range.
- Specified at 23 °C ± 1 °C with 50 % relative humidity.
- After a 1-hour warmup period.
- For 8 hours at 23 °C ± 1 °C with 50 % relative humidity.
- Output power is specified at connector output.
- Guaranteed at maximum power level.
- Dithered modulation is only available internally at a typical duty cycle of 50 % duty cycle.

## GENERAL SPECIFICATIONS

Size (H x W x D)	125 mm x 36 mm x 282 mm	4 <sup>15</sup> / <sub>16</sub> in x 1 <sup>7</sup> / <sub>16</sub> in x 11 <sup>1</sup> / <sub>8</sub> in
Weight	0.580 kg	1.25 lb
Temperature	Operating	10 °C to 40 °C
	Storage	-40 °C to 70 °C
Relative humidity	0 to 95 % non-condensing	

### Instruments Drivers

LabVIEW™ drivers, SCPI commands and COM/DCOM libraries

### Remote Control

With IQS-500: GPIB (IEEE-488.1, IEEE-488.2) Ethernet and RS-232.

### Standard Accessories

User guide, test report and Certificate of Compliance.

ORDERING INFORMATION

IQS-24**XX**BLD-**XX**-**XX**-**XX**

Wavelength band ■

- 02 = 1308 nm
- 03 = 1528-1565 nm C-band
- 04 = 1566-1606 nm L-band

Options code ■

- P3 = user-provided DFB(s) (Call factory)
- P4 = +10 dBm
- P5 = +10 dBm with PMF output<sup>b</sup>
- P6 = +13 dBm
- P7 = +13 dBm with PMF output<sup>b</sup>

Notes

- a. When PM fiber is selected, the slow axis is aligned with the connector key.

Connector code ■

- 96 = E-2000/APC<sup>a</sup>
- EA-EUI-89 = APC/FC
- EA-EUI-91 = APC/SC
- EA-EUI-95 = APC/E-2000

Specified wavelength (nm)

96 = 1528.77	29 = 1554.94	62 = 1582.02
97 = 1529.55	30 = 1555.75	63 = 1582.85
98 = 1530.33	31 = 1556.55	64 = 1583.69
99 = 1531.12	32 = 1557.36	65 = 1584.53
00 = 1531.90	33 = 1558.17	66 = 1585.36
01 = 1532.68	34 = 1558.98	67 = 1586.20
02 = 1533.47	35 = 1559.79	68 = 1587.04
03 = 1534.25	36 = 1560.61	69 = 1587.88
04 = 1535.04	37 = 1561.42	70 = 1588.73
05 = 1535.82	38 = 1562.23	71 = 1589.57
06 = 1536.61	39 = 1563.05	72 = 1590.41
07 = 1537.40	40 = 1563.86	73 = 1591.26
08 = 1538.19	41 = 1564.68	74 = 1592.10
09 = 1538.98	42 = 1565.50	75 = 1592.95
10 = 1539.77	43 = 1566.31	76 = 1593.79
11 = 1540.56	44 = 1567.13	77 = 1594.64
12 = 1541.35	45 = 1567.95	78 = 1595.49
13 = 1542.14	46 = 1568.77	79 = 1596.34
14 = 1542.94	47 = 1569.59	80 = 1597.19
15 = 1543.73	48 = 1570.43	81 = 1598.04
16 = 1544.53	49 = 1571.24	82 = 1598.89
17 = 1545.32	50 = 1572.06	83 = 1599.75
18 = 1546.12	51 = 1572.89	84 = 1600.60
19 = 1546.92	52 = 1573.71	85 = 1601.46
20 = 1547.72	53 = 1574.54	86 = 1602.31
21 = 1548.51	54 = 1575.37	87 = 1603.17
22 = 1549.32	55 = 1576.20	88 = 1604.03
23 = 1550.12	56 = 1577.03	89 = 1604.89
24 = 1550.92	57 = 1577.86	90 = 1605.74
25 = 1551.72	58 = 1578.69	CU = 1308
26 = 1552.52	59 = 1579.52	
27 = 1553.33	60 = 1580.35	
28 = 1554.13	61 = 1581.18	

SAFETY

Class 1M  
21 CFR 1040.10 and 1040.11  
IEC 60825-1

**EXFO Corporate Headquarters** > 400 Godin Avenue, Quebec City (Quebec) G1M 2K2 CANADA | Tel.: +1 418 683-0211 | Fax: +1 418 683-2170 | info@EXFO.com

Toll-free: +1 800 663-3936 (USA and Canada) | [www.EXFO.com](http://www.EXFO.com)

<b>EXFO America</b>	3701 Plano Parkway, Suite 160	Plano, TX 75075 USA	Tel.: +1 800 663-3936	Fax: +1 972 836-0164
<b>EXFO Asia</b>	151 Chin Swee Road, #03-29 Manhattan House	SINGAPORE 169876	Tel.: +65 6333 8241	Fax: +65 6333 8242
<b>EXFO China</b>	Beijing New Century Hotel Office Tower, Room 1754-1755 No. 6 Southern Capital Gym Road	Beijing 100044 P. R. CHINA	Tel.: +86 (10) 6849 2738	Fax: +86 (10) 6849 2662
<b>EXFO Europe</b>	Omega Enterprise Park, Electron Way	Chandlers Ford, Hampshire S053 4SE ENGLAND	Tel.: +44 2380 246810	Fax: +44 2380 246801
<b>EXFO Service Assurance</b>	285 Mill Road	Chelmsford, MA 01824 USA	Tel.: +1 978 367-5600	Fax: +1 978 367-5700

EXFO is certified ISO 9001 and attests to the quality of these products. This device complies with Part 15 of the FCC Rules. Operation is subject to the following two conditions: (1) this device may not cause harmful interference, and (2) this device must accept any interference received, including interference that may cause undesired operation. EXFO has made every effort to ensure that the information contained in this specification sheet is accurate. However, we accept no responsibility for any errors or omissions, and we reserve the right to modify design, characteristics and products at any time without obligation. Units of measurement in this document conform to SI standards and practices. In addition, all of EXFO's manufactured products are compliant with the European Union's WEEE directive. For more information, please visit [www.EXFO.com/recycle](http://www.EXFO.com/recycle). Contact EXFO for prices and availability or to obtain the phone number of your local EXFO distributor.

For the most recent version of this spec sheet, please go to the EXFO website at <http://www.EXFO.com/specs>

In case of discrepancy, the Web version takes precedence over any printed literature.